



JUNE 2020

Terra AC Wallbox

Loadmanagement

Terra AC Load Management

Overview

Static w/ single charger



Static w/ single charger



Hybrid w/ multiple chargers

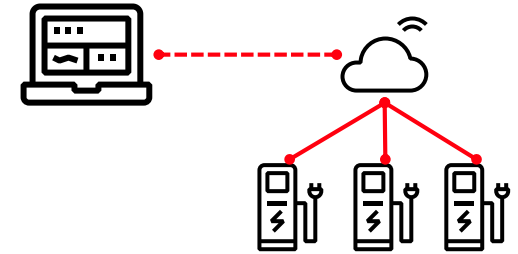

Dynamic w/ single charger

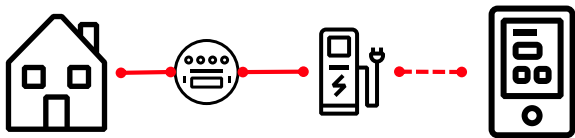

Dynamic w/ multiple chargers

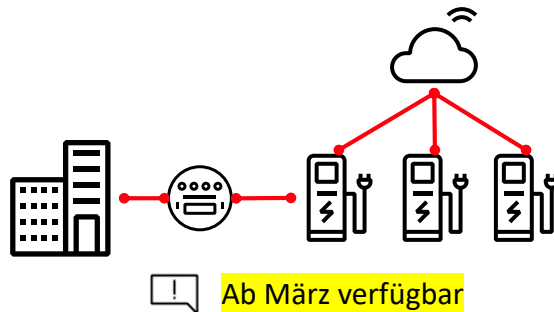

Dynamic w/ multiple chargers via local controller

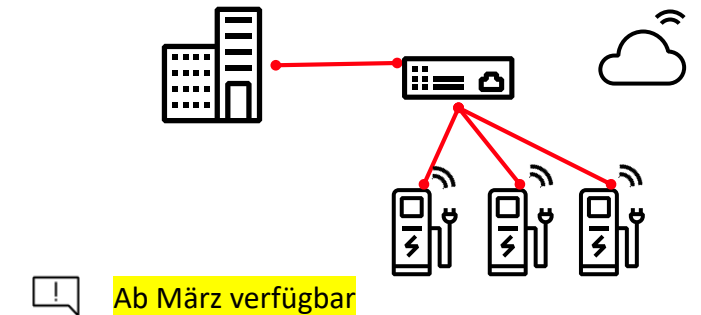

— Static load management with Terra AC

Terra AC Load Management

Static w/ single charger



Home / Single use case scenario

- 1 Terra AC
- No connectivity (WiFi, LAN, 4G) needed
- Connection via Bluetooth on TerraConfig App (Installer / Technical support)
- Configuration done when commissioning
Setting the current limit in accordance with the grid's remaining capacity for the charger
- Goal is to protect the fuse
- Solid configuration that can only be changed by another installer/ technical support engineer, therefore cannot be changed by the end user



no extra hardware needed

TerraConfig App



Terra AC Load Management

Static w/ single charger



Home / Single use case scenario

- 1 Terra AC
- No connectivity (WiFi, LAN, 4G) needed
- Connection via Bluetooth on the ChargerSync App (EV driver)
- Configuration can be done at any time (even while there is an ongoing charging session)
- Goal is to let the EV driver decide the maximum value of current the EV will charge with*

 no extra hardware needed

*Depends on the EV's SoC

ChargerSync App

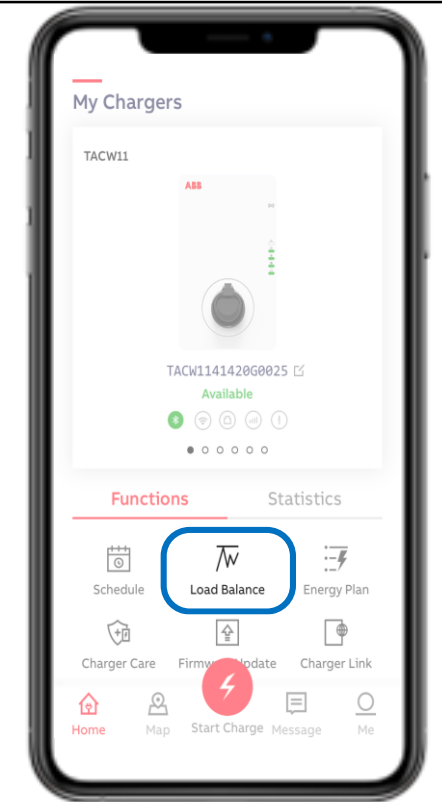
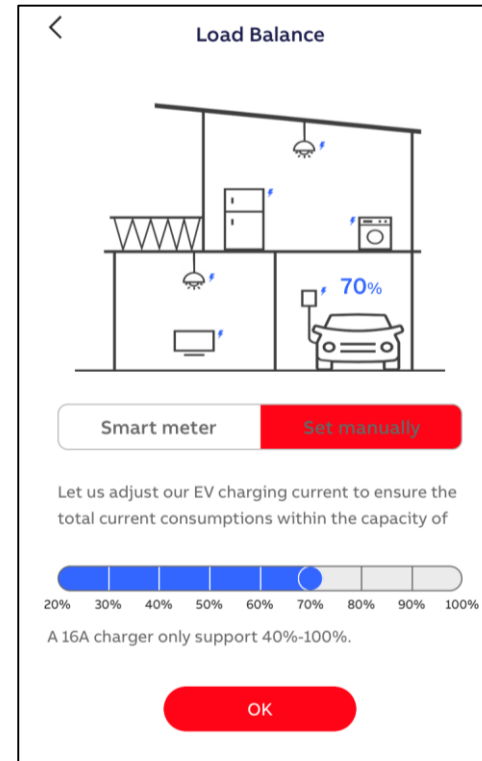

Terra AC Load Management

Static w/ single charger



Local business use case scenario

- x number of Terra ACs
- Connectivity (WiFi, LAN, 4G) to ABB backend/server needed
- Connection via internet on the ChargerSync Essentials Operational Portal
- Configuration can be done at any time (even while there is an ongoing charging session)
- Goal is to let the operator(s) of these accounts handle the maximum current of their chargers individually
- If hybrid load balancing feature is on, (static) load balance cannot be used anymore (it becomes grey)



no extra hardware needed

ChargerSync Essentials Operational Portal

NO.	Alias/SN	Connector	Phase	Network	Status	Derating	Current	Remote Control
1	TACW1141420G0025 TACW1141420G0025			4G	Available	70%	11.2A	
2	TACW741320G0018 TACW741320G0018			4G	Available	100%	32A	

Hybrid load management with Terra AC

Terra AC Load Management

Hybrid w/ multiple chargers 1/4

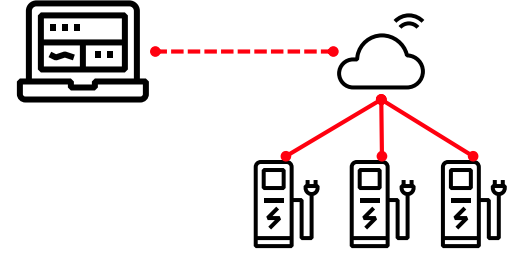

Big accounts use case scenario

- x number of Terra ACs in a charging site
- Connectivity (WiFi, LAN, 4G) to ABB backend/server needed
- Connection via internet on the ChargerSync Network Webportal
- 3 Priority groups for the chargers:
Medium (first to decrease current/power, delayed start charging);
High (second to decrease current/power, immediately start charging);
VIP (could not decrease, immediately start charging)
- Configuration can be done at any time
All chargers in a charging site must be entered in a priority group
- Goal is to let the operator(s) of big accounts handle their charging sites

*Not a free feature

ChargerSync Network* Webportal Hybrid Load Management

The screenshot displays the 'CHARGERSync' webportal interface. The top navigation bar includes 'Overview', 'Charging Site', 'User Management', and 'Charging Session'. The main content area is titled 'Load Control Option' and features two radio buttons: 'Option A: Load Management With Smart Meter' (unselected) and 'Option B: Load Management With Cloud Control' (selected). Below these are input fields for 'Electricity Capacity(kW)' (22), 'Regulation Coefficient(%)' (90), and 'Power Decrease Amplitude(%)' (60). To the right, there are two status indicators: 'Load Control Threshold(kW) 19.8' and 'Power Decrease Baseline(kW) 11.88'. A 'Description' section on the right contains a legend for 'Electricity Capacity', 'Load Control Threshold', 'Power Decrease Baseline', 'Power Reduction', and 'Power Increase', along with a bar chart showing power levels over time. The bottom section, 'Load Control Group', lists three groups: 'Priority Group 1' (Medium), 'Priority Group 2' (High), and 'Priority Group 3' (VIP), each with its own status and current charger count.

Terra AC Load Management

Hybrid w/ multiple chargers 2/4

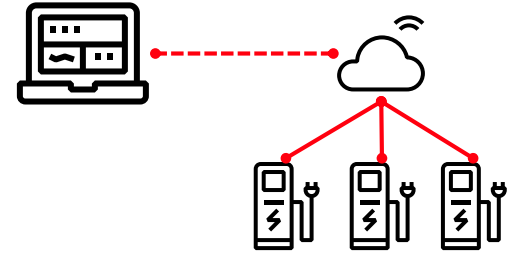

ChargerSync Network* Webportal Hybrid Load Management

- Electricity capacity:
The capacity of this charger site
- Regulation Coefficient:
To regulate the upper limits of the total output power of the chargers
- Power Decrease Amplitude:
To regulate the baseline of the total output power of the chargers

The screenshot shows the CHARGERSync C webportal interface. The top navigation bar includes 'Overview', 'Charging Site', 'User Management', and 'Charging Session'. The main content area is titled 'Load Control Option' and features three input fields: 'Electricity Capacity(kW)' set to 22, 'Regulation Coefficient(%)' set to 90, and 'Power Decrease Amplitude(%)' set to 60. Below these fields, two status indicators are shown: 'Load Control Threshold(kW) 19.8' and 'Power Decrease Baseline(kW) 11.88'. To the right, a 'Description' section includes a legend for 'Electricity Capacity', 'Load Control Threshold', 'Power Decrease Baseline', 'Power Reduction', and 'Power Increase'. A bar chart below the legend shows power levels over time, with annotations for 'Auto curtailment if above Load Control Threshold' and 'Auto growth if below Power Decrease Baseline'. A 'Site List' dropdown menu on the left shows 'test site Delft'.

The screenshot displays the 'Load Control Group' section of the webportal. It contains three priority groups, each with a star icon and a status indicator (Adjustable or Pausable).
- Priority Group 1 (Medium): Adjustable, Pausable, Current Chargers: 3. Alias: TACW1141420G0058.
- Priority Group 2 (High): Adjustable, Pausable, Current Chargers: 0. Alias: TACW1141420G0025.
- Priority Group 3 (VIP): Adjustable, Pausable, Current Chargers: 0. Alias: TACW741320G0018.

Terra AC Load Management

Hybrid w/ multiple chargers 3/4

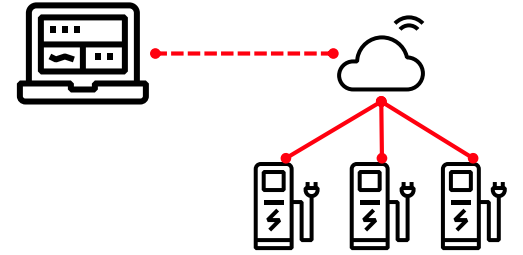

Big accounts use case scenario

- Main function: Cloud acts as master, chargers as slaves. It's a hybrid way of balancing because it acts as static to the grid limitation but as dynamic to the cluster itself

Hybrid Load Management

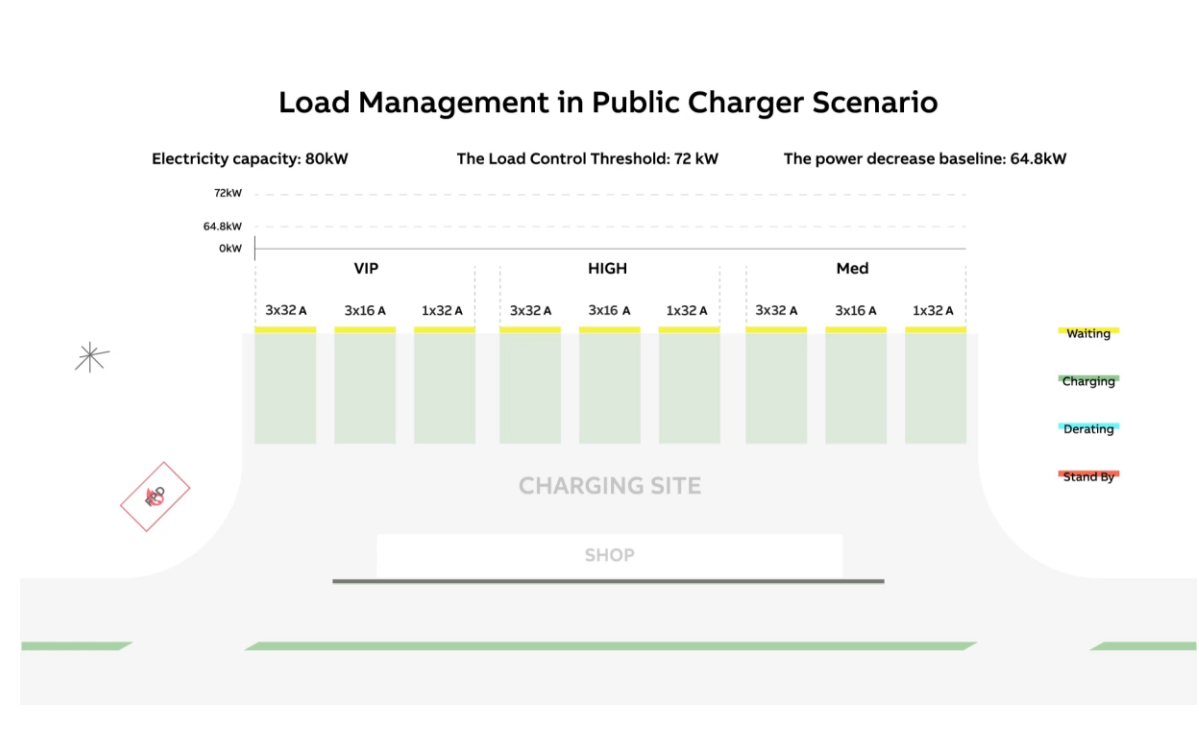

 no extra hardware needed

Terra AC Load Management

Hybrid w/ multiple chargers 4/4

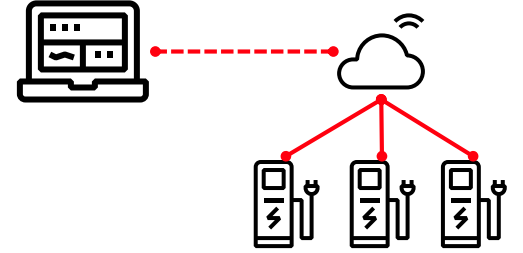

Hybrid Load Management

Load Management in Public Charger Scenario

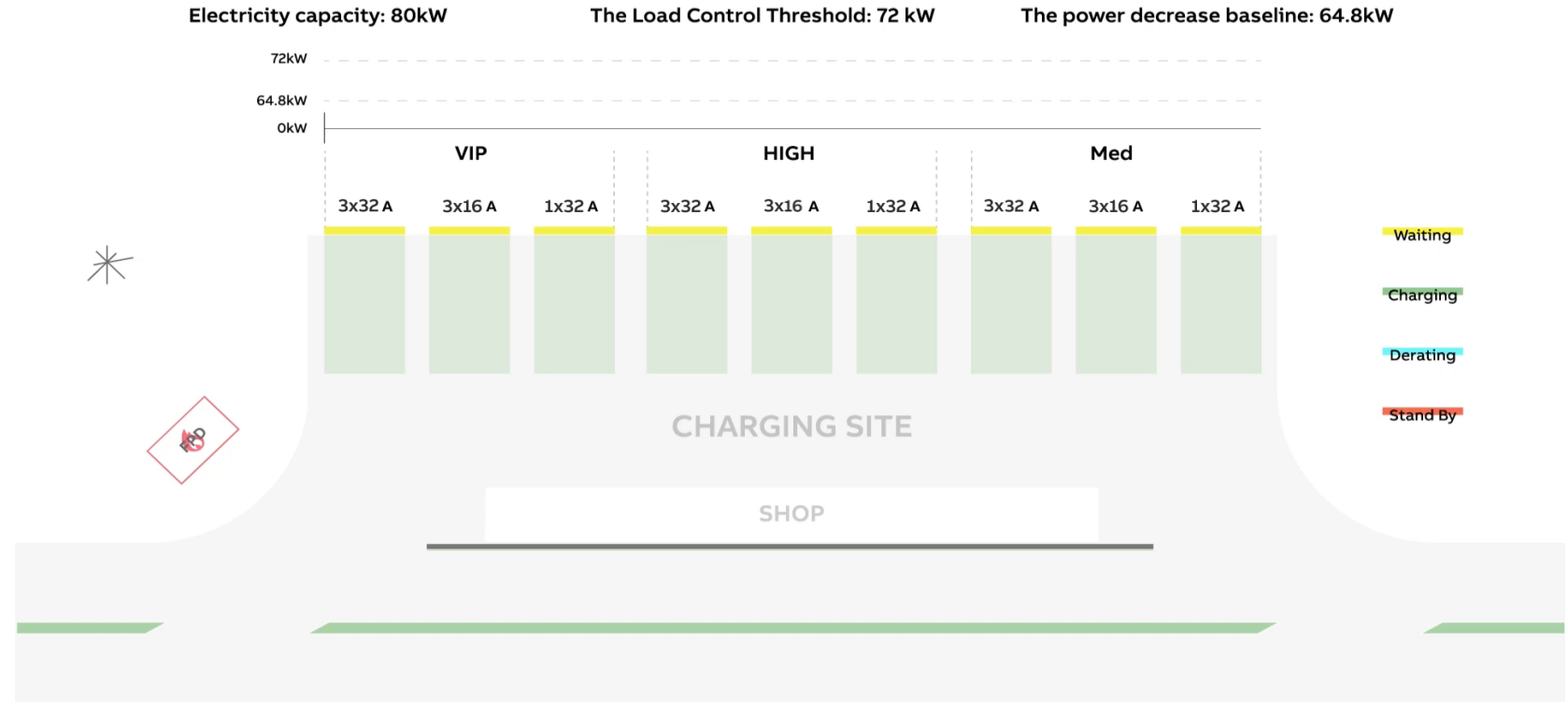

—

Dynamic load management with Terra AC

Terra AC Load Management

Local Dynamic w/ single charger 1/2

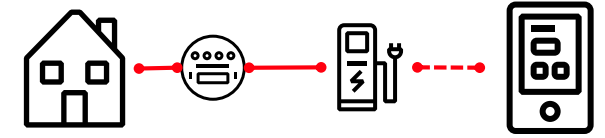

Home / Single use case scenario

- 1 Terra AC
- No connectivity (WiFi, LAN, 4G) needed
- Connection via Bluetooth on TerraConfig App (Installer) for setting the parameters of smart meter
- Connection via Bluetooth on Chargersync App (EV driver) for setting the parameters of the specific use case

Overview of the EVSE, inside

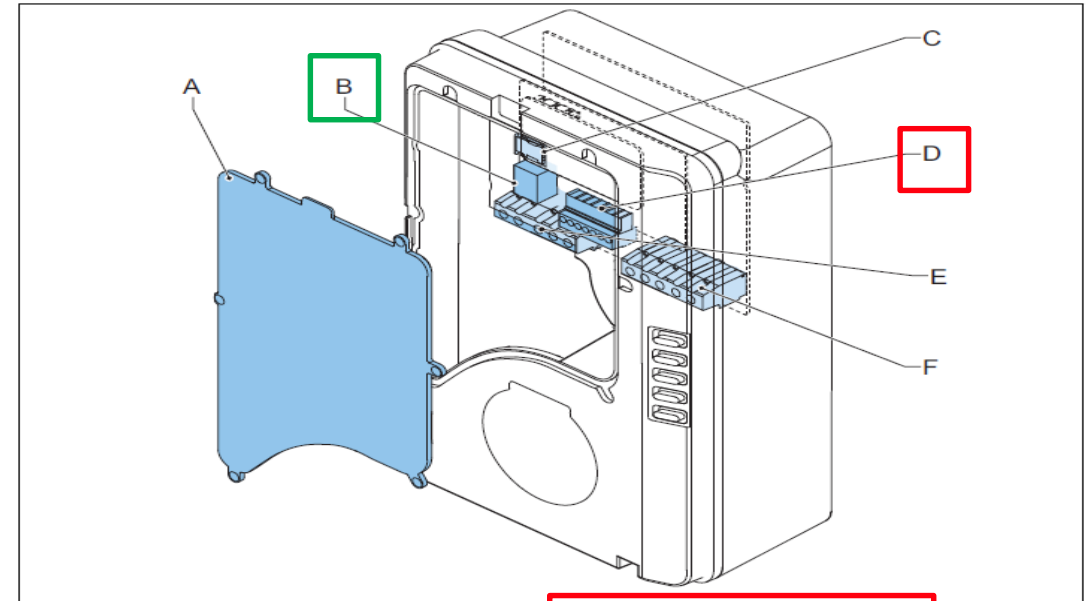

A Maintenance cover
B Ethernet connection
C Socket for a Nano-SIM card

D Smart meter connection
E Terminal block for the AC input
F Terminal block for the EV charge cable or the socket

Terra AC Load Management

Local Dynamic w/ single charger 2/2

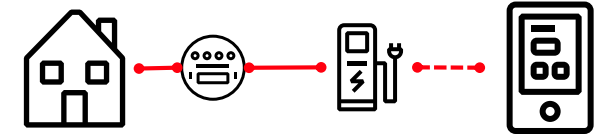

Home / Single use case scenario

- The meter values are transmitted via the RS485 cable from the smart meter to the Terra AC and the charger acts accordingly

 extra hardware needed (smart meter)

Example of a Terra AC with a smart meter

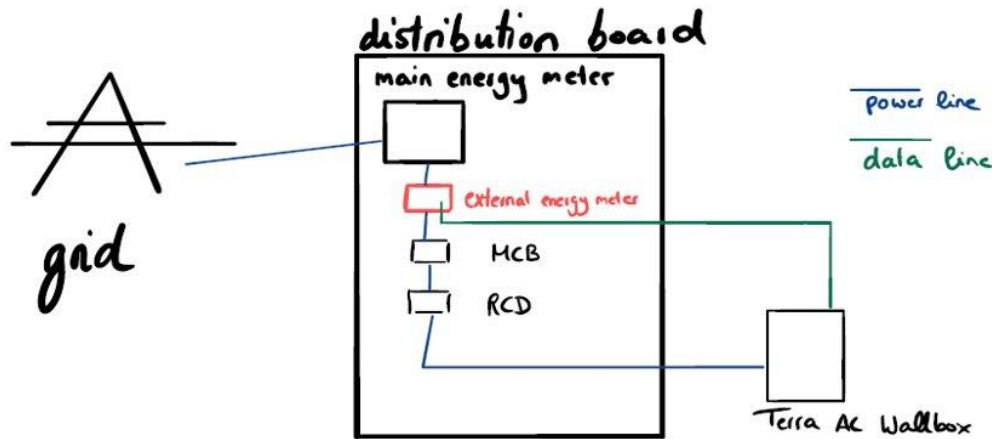

Feature of ChargerSync App

- Electricity capacity: Maximum electricity capacity of your residence
- Load Threshold: Current of charger will decrease when this limit is reached
- Power Decrease Baseline (%): Current of charger will increase when this baseline is reached

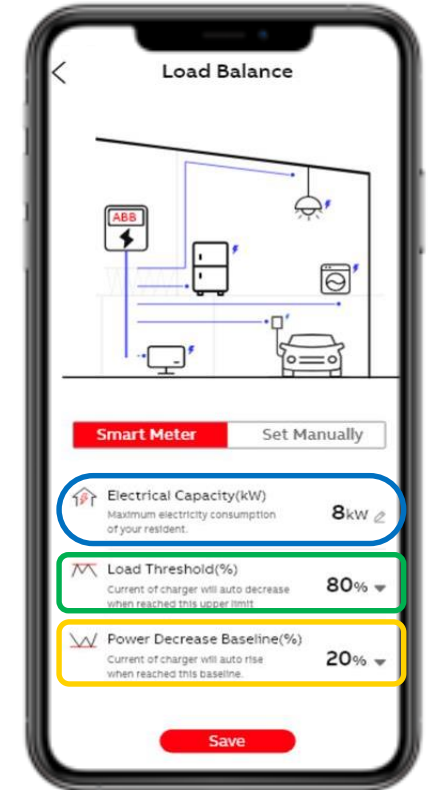

Terra AC Load Management

Remote Dynamic w/ multiple chargers 1/2

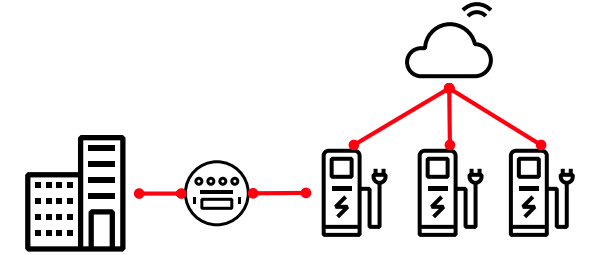

Big accounts use case scenario

- x number of Terra ACs
- Connectivity (WiFi, LAN, 4G) to ABB backend/server needed
- Connection via Bluetooth on TerraConfig App (Installer) for setting the parameters of smart meter
- Connection via internet to Chargersync Network Web portal for setting the parameters of the specific use case
- Only 1 charger is connected to the smart meter.
The meter values are transmitted via the RS485 cable from the smart meter to the paired Terra AC and then to the cloud, which acts like a “master” and the Terra ACs as “slaves” (algorithm on cloud).
- Allocation of the chargers to priority groups (load control group)



extra hardware needed (smart meter)

ChargerSync Network Web portal

The screenshot shows the ChargerSync Network Web portal interface. The top navigation bar includes 'CHARGERSync', 'Overview', 'Charging Site', 'User Management', and 'Charging Session'. The main content area is titled 'Load Control Option' and features two radio button options: 'Option A: Load Management With Smart Meter' (selected) and 'Option B: Load Management With Cloud Control'. Under Option A, there are input fields for 'Electricity Capacity(kW)' (22), 'Master Charger SN' (TACW1141420G0025), 'Regulation Coefficient(%)' (90), 'Communication Protocol' (dropdown), and 'Power Decrease Amplitude(%)' (90). A 'Description' section on the right includes a legend for 'Electricity Capacity', 'Load Control Threshold', 'Power Decrease Baseline', 'Power Reduction', and 'Power Increase', along with a bar chart showing power levels and thresholds. Below this, the 'Load Control Group' section displays three groups: 'Priority Group 1' (Medium), 'Priority Group 2' (High), and 'Priority Group 3' (VIP), each with its own set of adjustable and pausable settings and a list of associated Terra ACs.

Terra AC Load Management

Remote Dynamic w/ multiple chargers 2/2

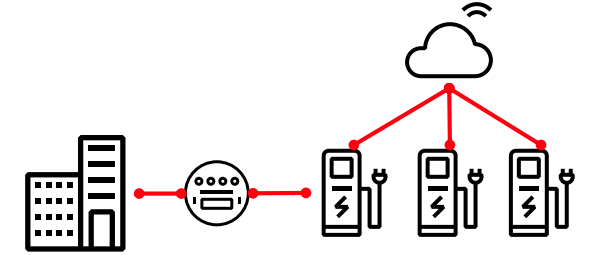

ChargerSync Network Web portal

- Master Charger SN:
The serial number of charger that is paired with smart meter
- Communication protocol:
Modbus RTU or TCP/IP
- Parameters' definitions:
(see slide 18)

The screenshot shows the 'Load Control Option' configuration page in the ChargerSync Network Web portal. The page is titled 'CHARGERSync' and has navigation tabs for 'Overview', 'Charging Site', 'User Management', and 'Charging Session'. The current site is 'test site Delft'. The configuration is for 'Option A: Load Management With Smart Meter'. The parameters are:

- Electricity Capacity(kw): 22
- Master Charger SN: TACW1141420G0025
- Communication Protocol: (dropdown menu)
- Regulation Coefficient(%): 90
- Power Decrease Amplitude(%): 90

Option B: Load Management With Cloud Control is also visible but not selected. A 'Description' section on the right includes a legend for Electricity Capacity, Load Control Threshold, Power Decrease Baseline, Power Reduction, and Power Increase. Below the legend is a bar chart showing power levels over time, with annotations for 'Auto curtailment if above Load Control Threshold', 'Regulation Coefficient', 'Auto growth if below Power Decrease Baseline', and 'Power Decrease Amplitude'.

The screenshot shows the 'Load Control Group' configuration page. It displays three priority groups:

- Priority Group 1** (Medium): Adjustable, Pausable, Current Chargers: 3. Alias: TACW1141420G0058, TACW1141420G0058.
- Priority Group 2** (High): Adjustable, Pausable, Current Chargers: 0. Alias: TACW1141420G0025, TACW1141420G0025.
- Priority Group 3** (VIP): Adjustable, Pausable, Current Chargers: 0. Alias: TACW741320G0018, TACW741320G0018.

Terra AC Load Management

Dynamic w/ multiple chargers via Local Controller (external device)

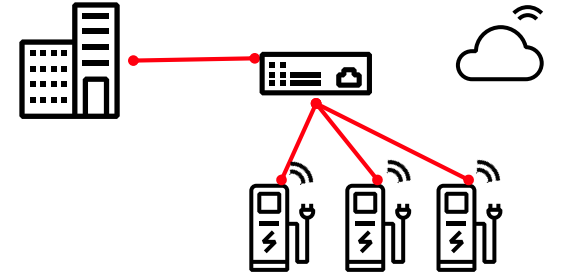

Big accounts use case scenario

- x number of Terra ACs
- Connectivity (WiFi, LAN, 4G) to ABB backend/server needed
- Chargers and controller need to be at the same local network
- Configuration done when commissioning by the installer
- The local controller acts like a “master” and the Terra ACs as “slaves”.

A set of chargers which are connected to a local load management controller as slave(s), receive an assigned current budget to be used. The assigned budget can be applied ad-hoc or with a dedicated start and end time. The charger sends back actual charging current and status of the charger.



extra hardware needed (local controller)

ABB